

State-of-the-art bagging technology

Engelbert Koess
Haver & Boecker,
Oelde / GERMANY

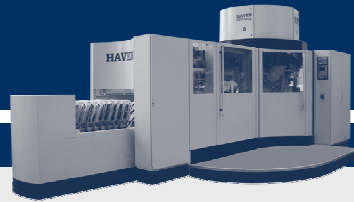

Demands on a Packing Machine



- high capacity
- high filling level
- improved cleanliness
- high weight accuracy
- automatic operation
- flexibility
- low maintenance



HAVER filling systems

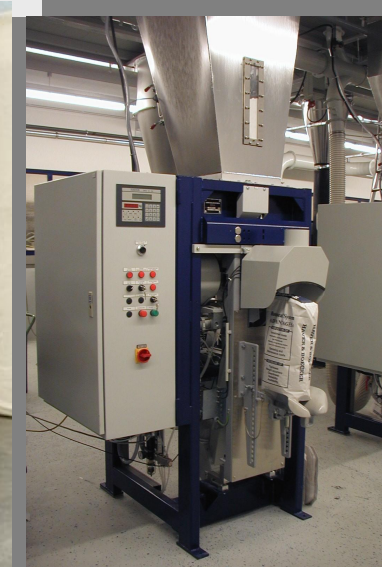

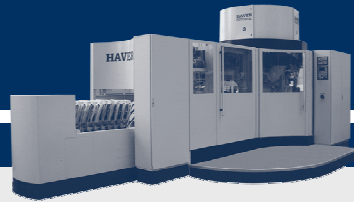

The bagging triangle

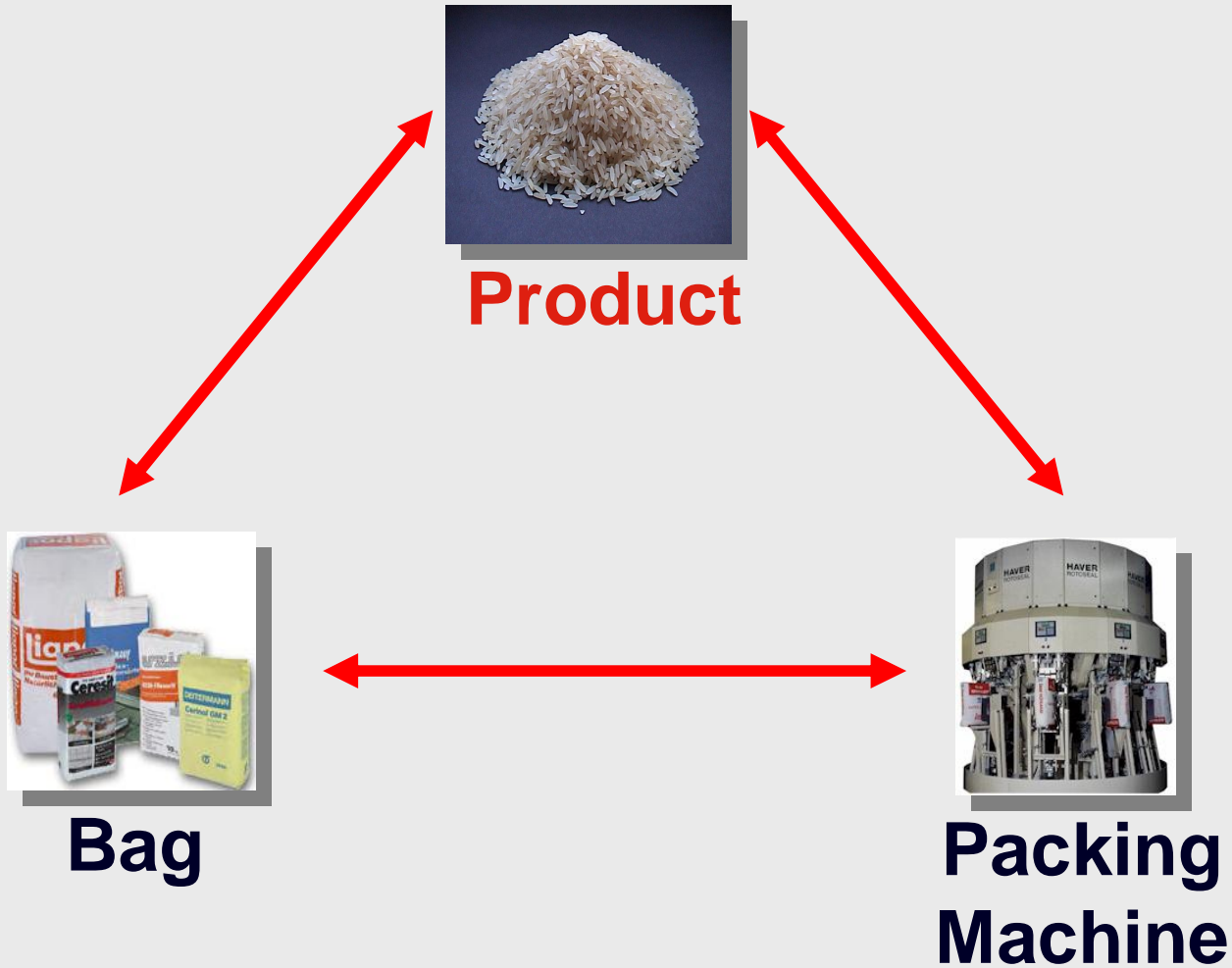

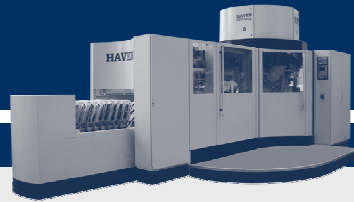

**HAVER
EML**



**HAVER
Air Flow Tester**



**HAVER
Big Gurly**



**HAVER
Trickle Tester**



**HAVER
Bulk Density Tester**



**HAVER
Aeration Measuring Column**



PARTICLE SIZE DISTRIBUTION



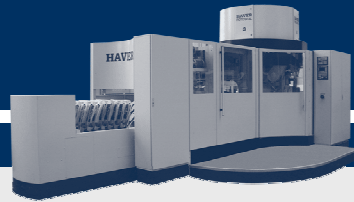

Special designed filling system for different products

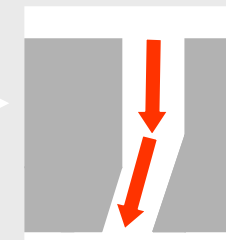
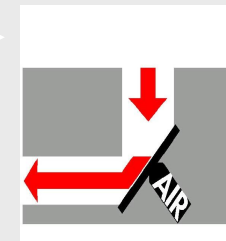
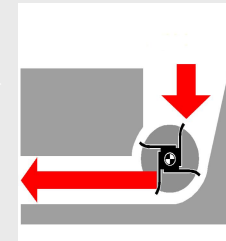
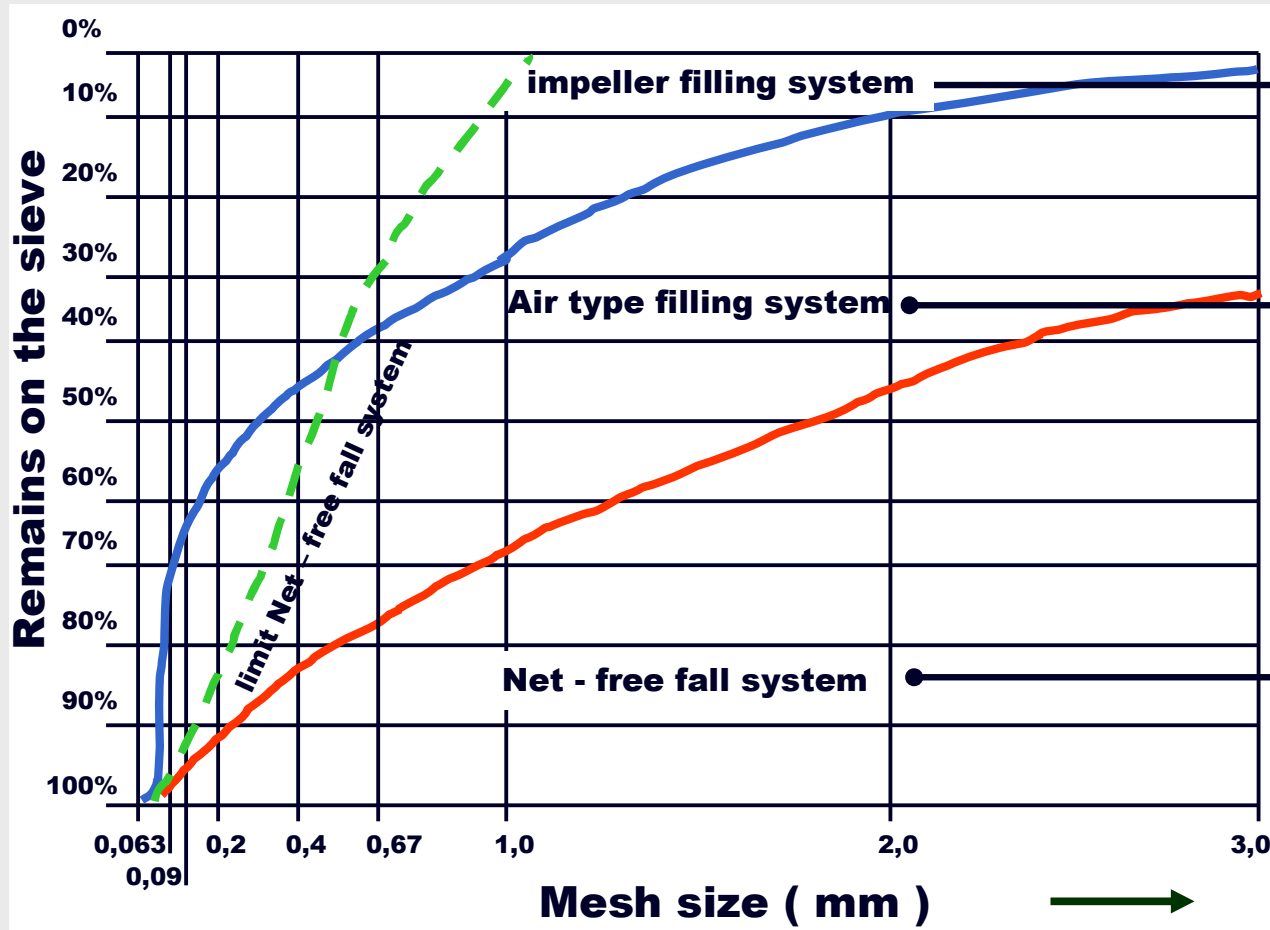

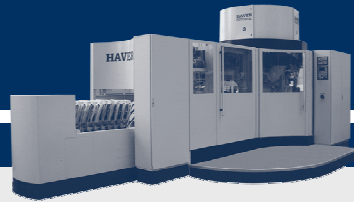

Aerating Property Distinction by HAVER & BOECKER

HAVER Aeration Measuring Column

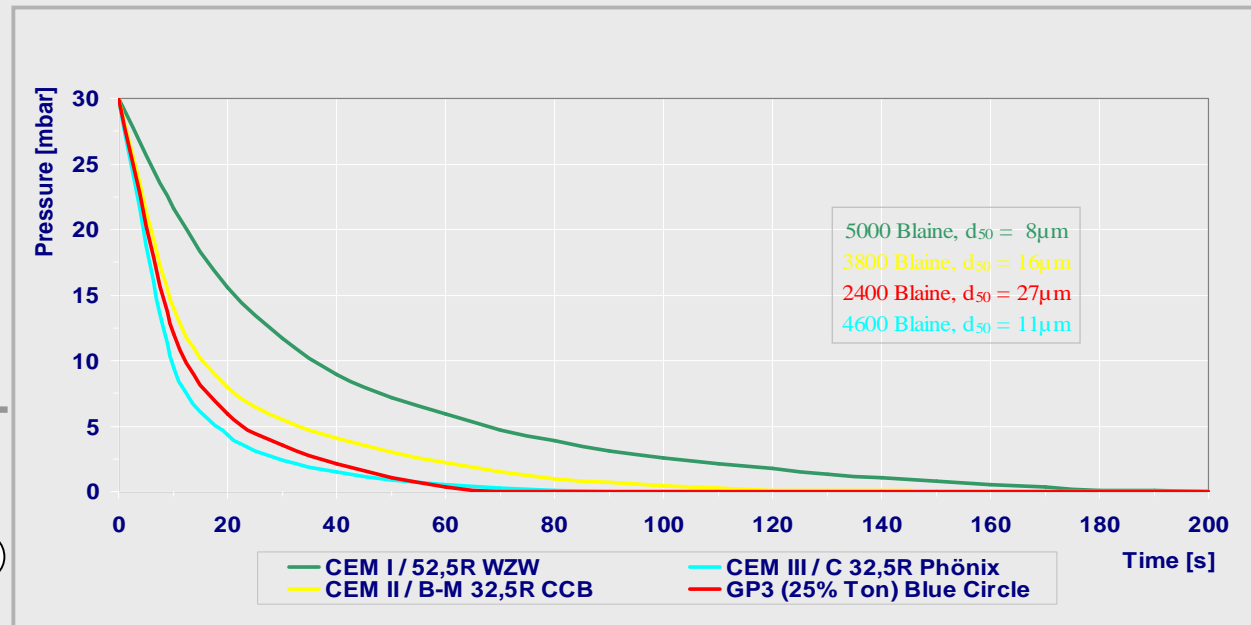
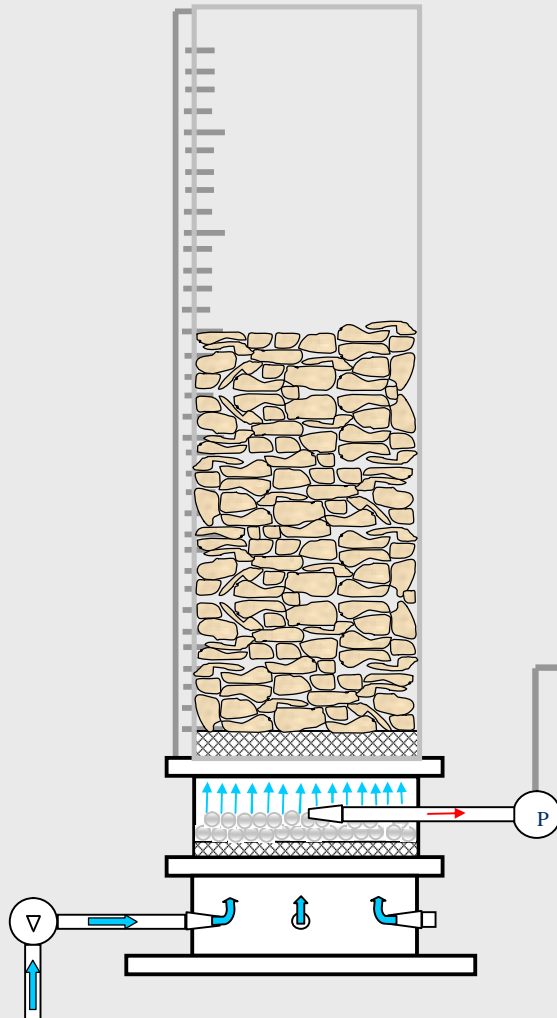

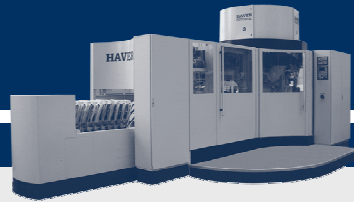

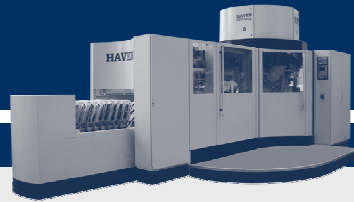

Dichtevergleich Trollius Weißkalk - Hydrat

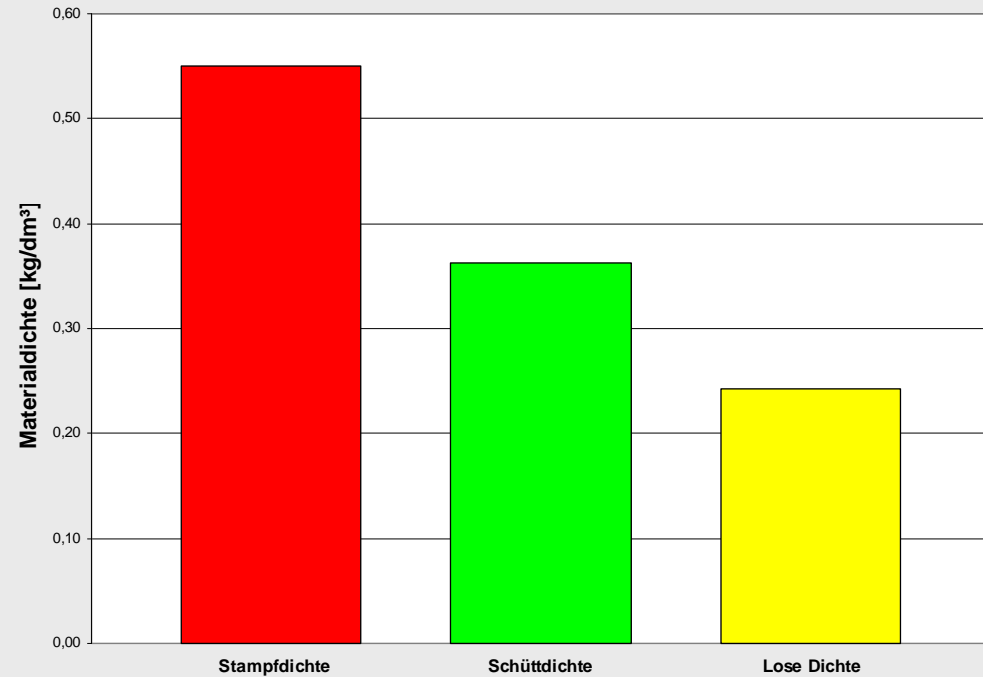

**Loose density: 0,242 kg/l bulk density: 0,363 kg/l tamped density: 0,550 kg/l
 after 1900 strokes**

Bulk density of products after compaction according to DIN ISO 787.



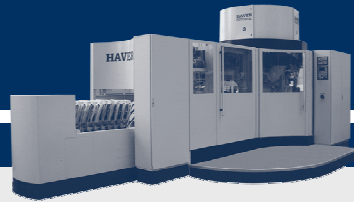

The bagging triangle

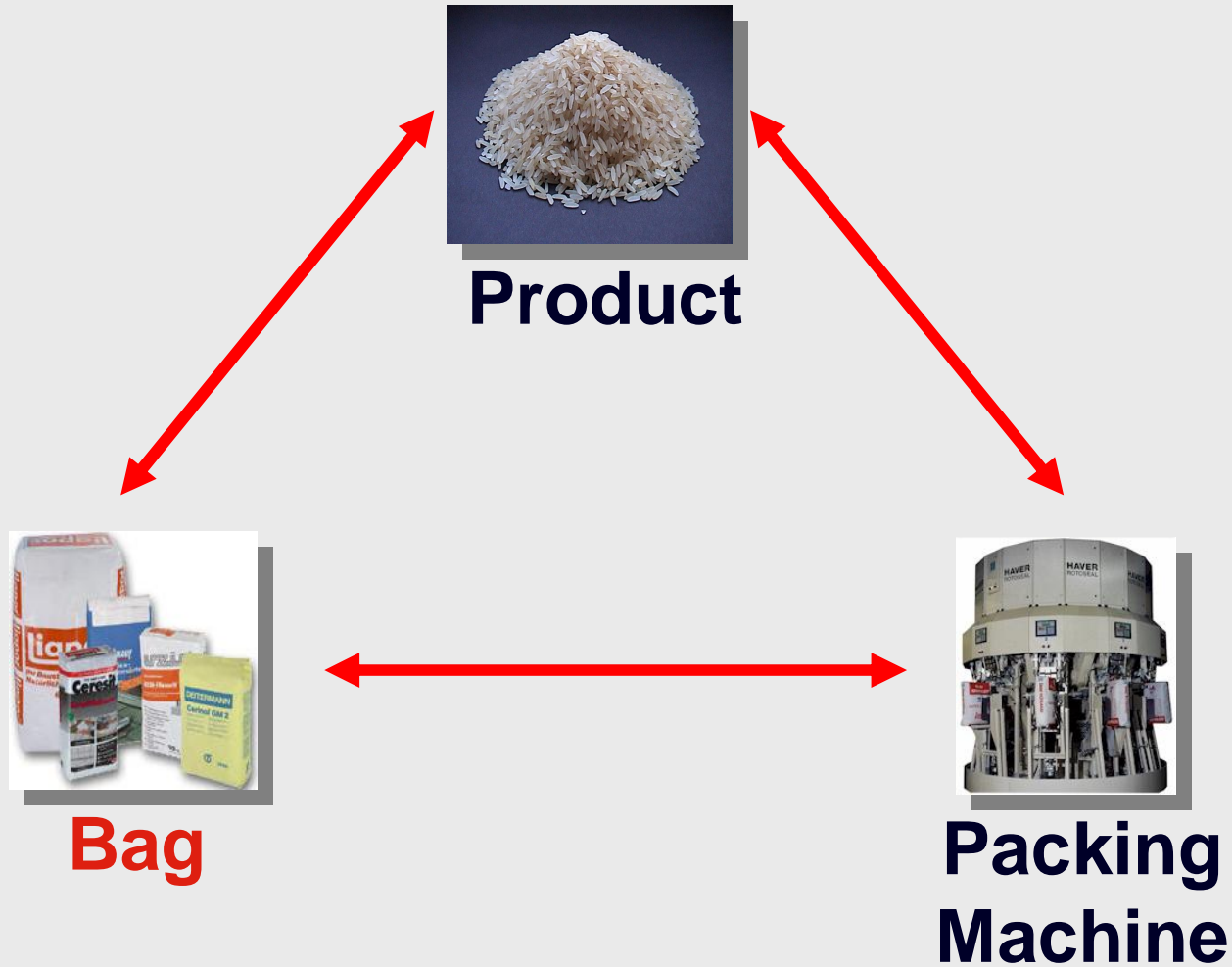



Empty bag bundles
not suitable for
automatic bag handling



HAVER Air Flow Tester



HAVER Big Gurly



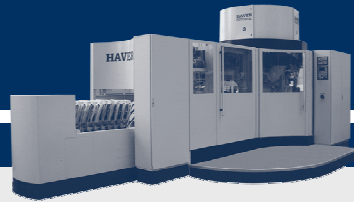

The bagging triangle

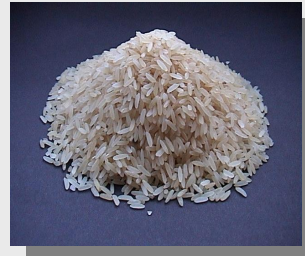

Product



Bag



Packing Machine

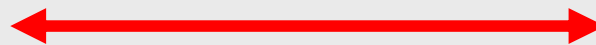

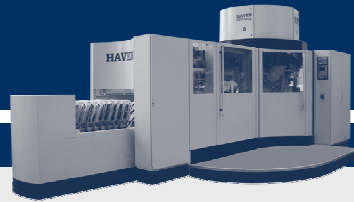

R+D Center



Computer Based Filling Tests

- Filling velocity
- Filling pressure
- Counter pressure
- Material compaction



The Impeller System

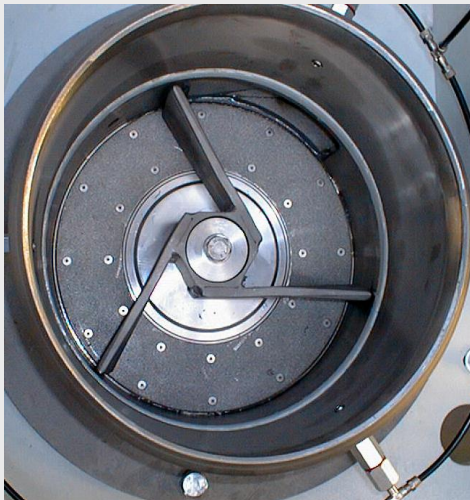
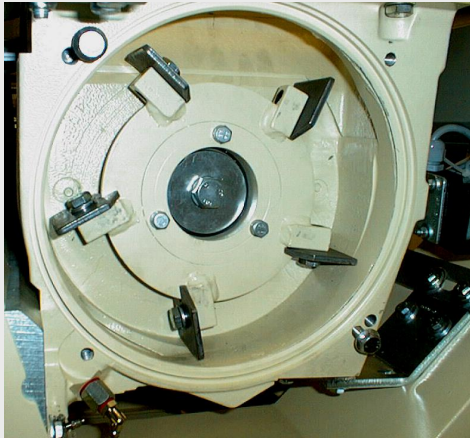

- impeller size
- revolutions per minute
- vertical/horizontal impeller
- type of impeller blade
- number of the impeller blades
- dia. of the filling channel
- aeration ...

... engineered to suit your product

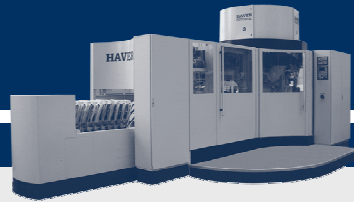

- Diagram Filling Cycle -

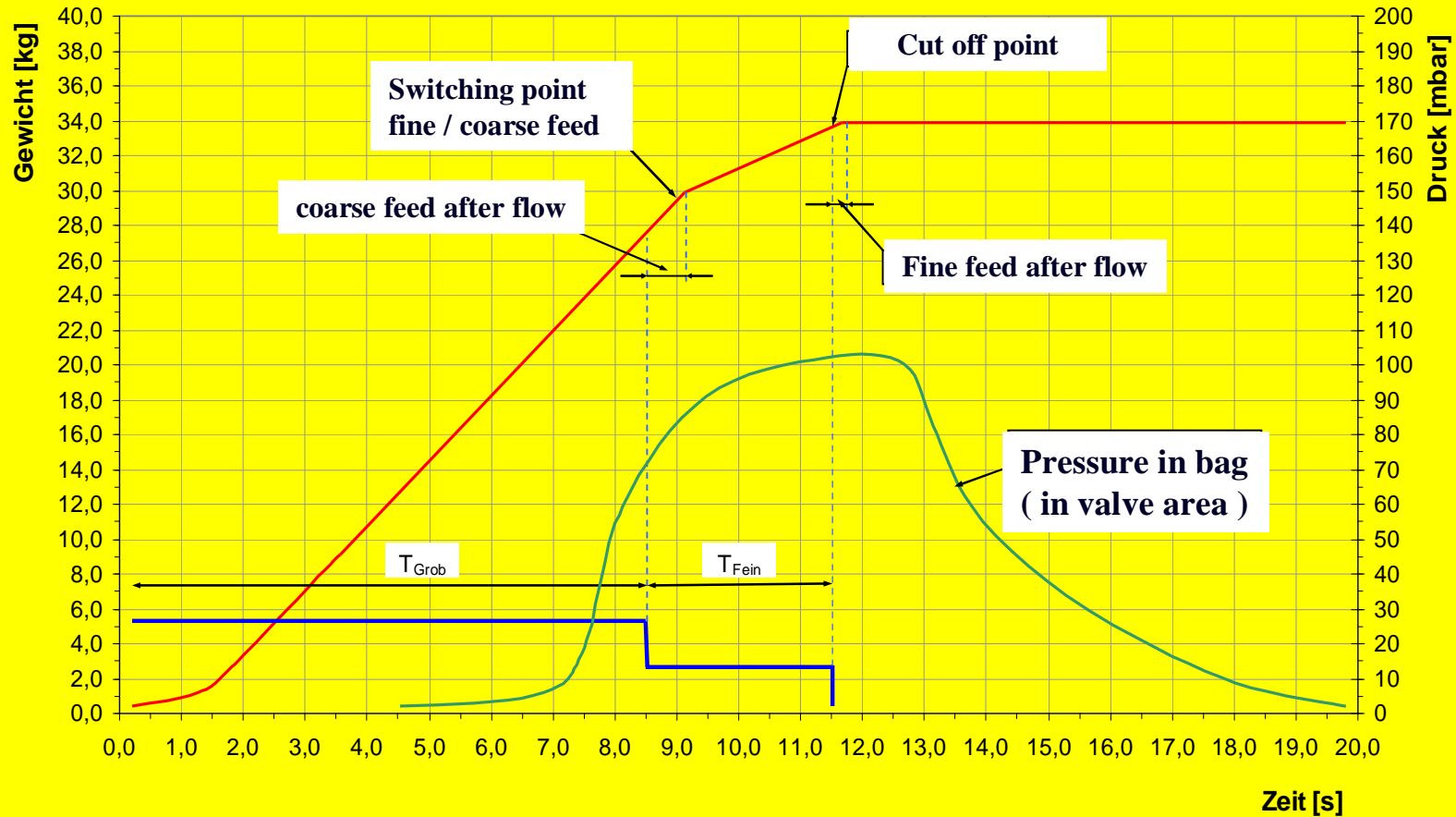

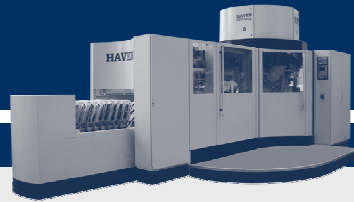

areation with ring jet

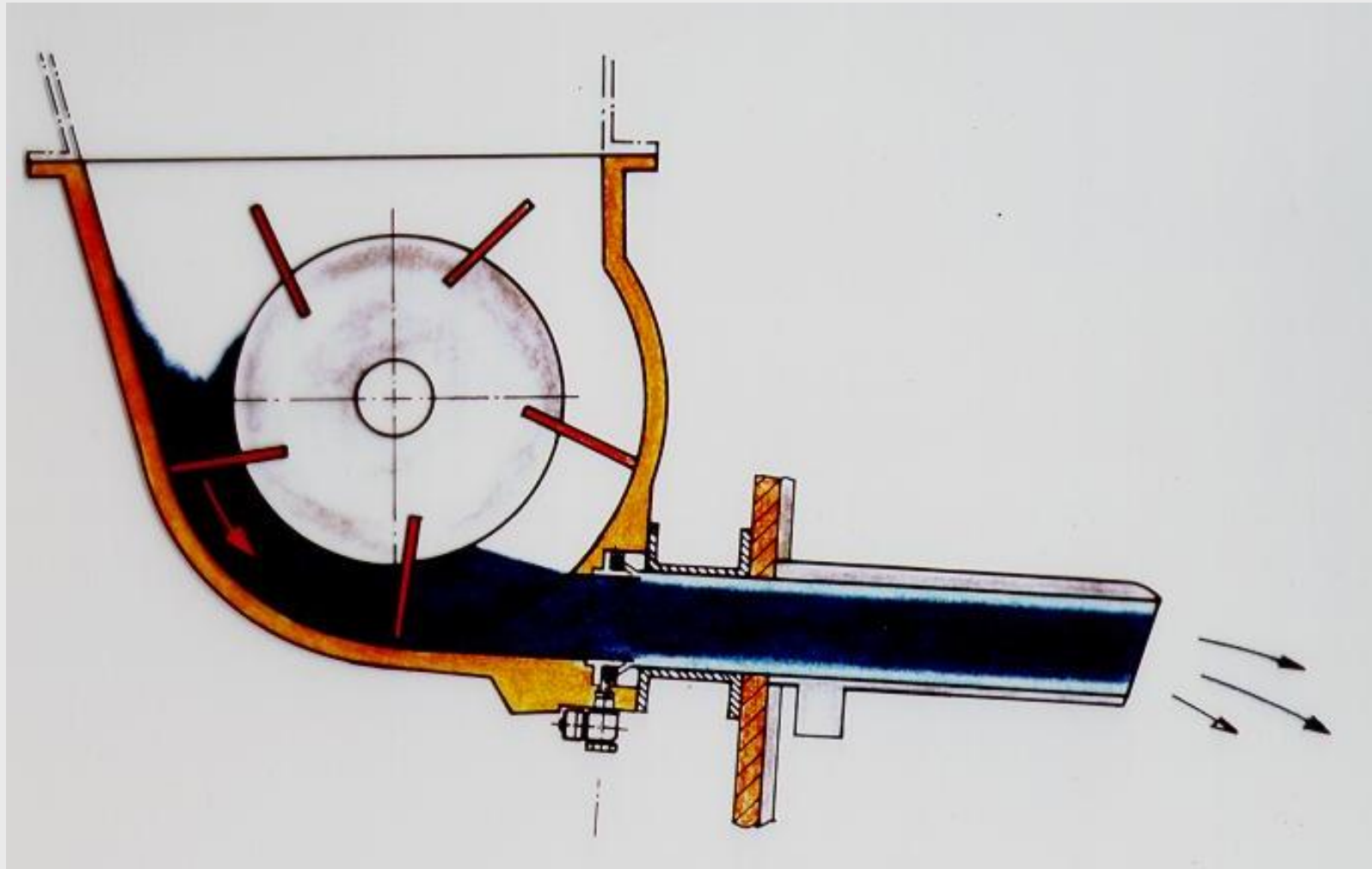



AERATION AND DE-AERATION DURING FILLING WITH VERTICAL IMPELLER

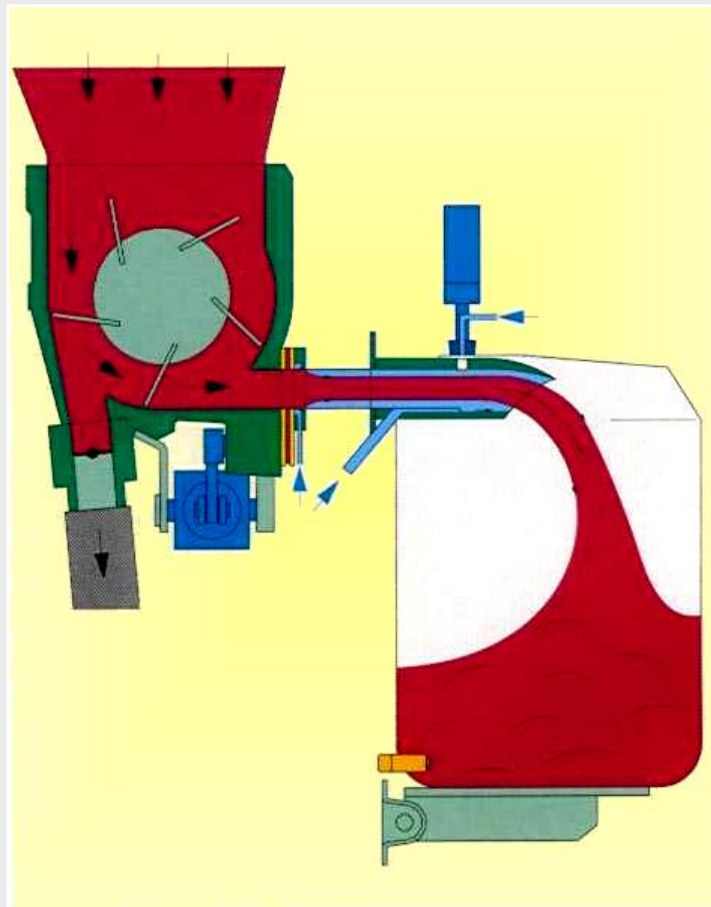

- reduction of wall friction in the filling channel via minimized aeration by means of ring gap aeration
- ring gap aeration prevents, that air is reaching the core of the product
- amount of aeration is depending on the filling speed
- this results in a clean filling process under high filling pressure and thus in a dense packing

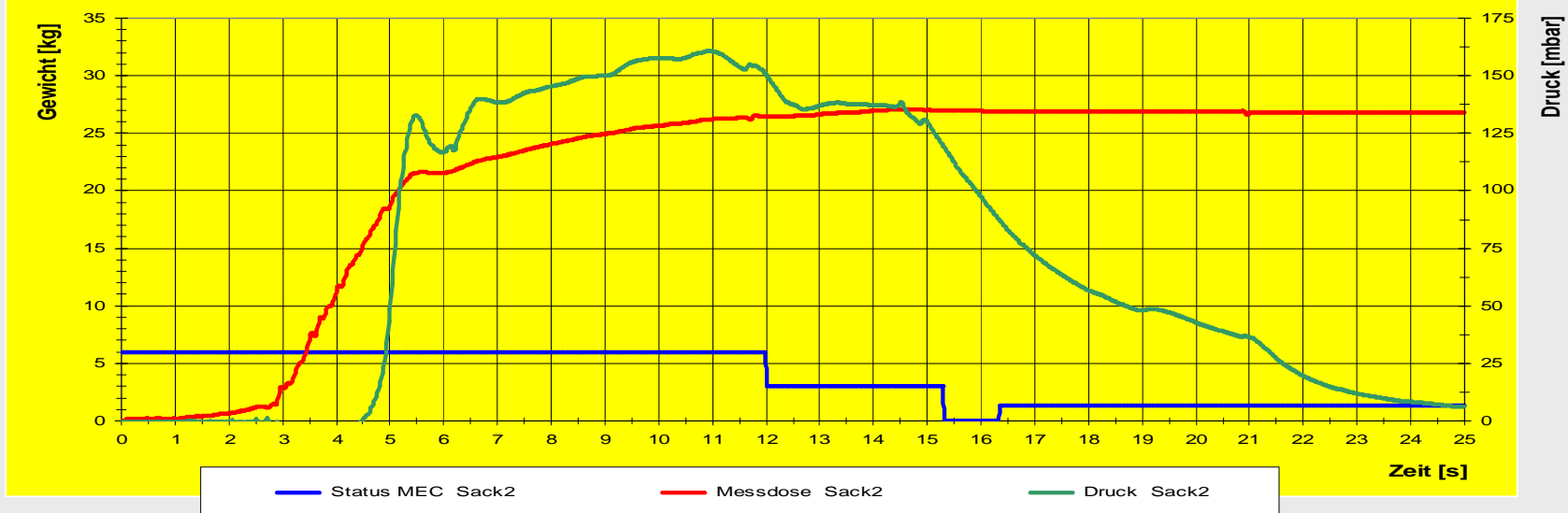
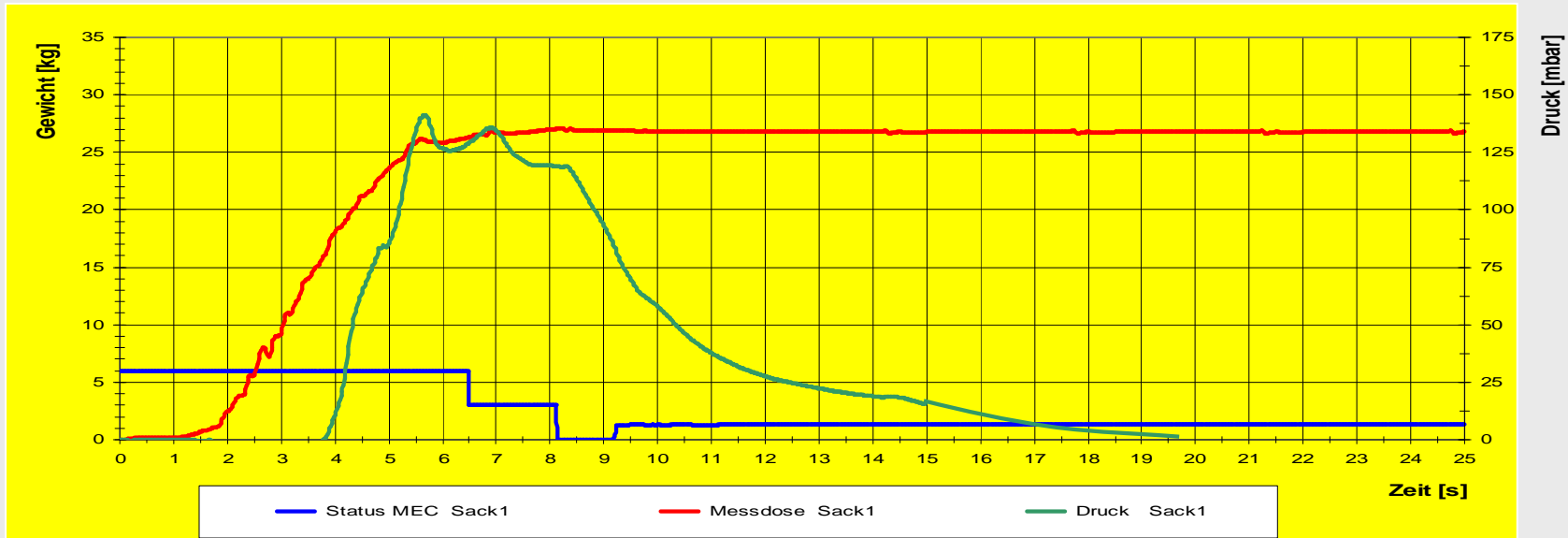
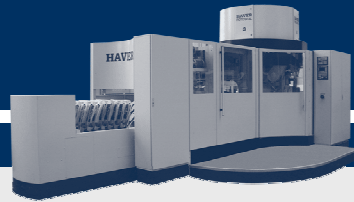

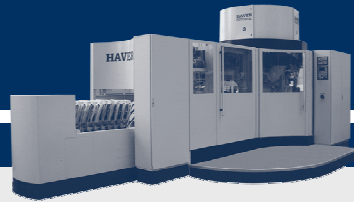

1 filling spout

manual bag placing

**manual discharge
of the filled bag**

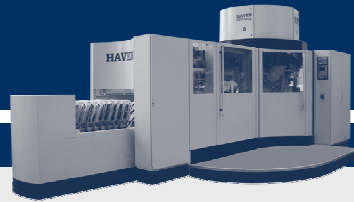

Inline packer

2 filling spouts

manual bag placing

**automatic discharge
of the filled bag**



Inline packer

3 filling spouts

automatic bag placing

**automatic discharge
of the filled bag**



**The HAVER ROTO-Packer
(Impeller)**

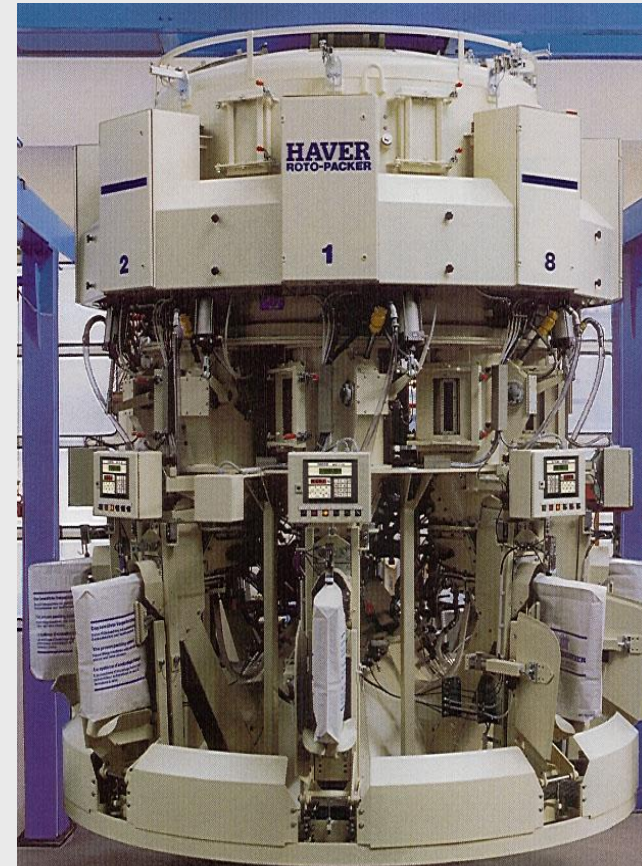

**The HAVER ROTO-Packer
(Pneumatic)**



Advantages of the **HAVER ROTO-Packer**

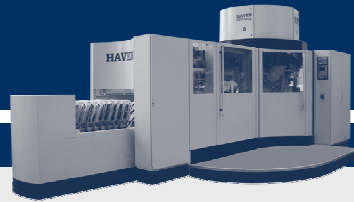

Advantages of ROTO-Packer solution against Inline-Packer solution

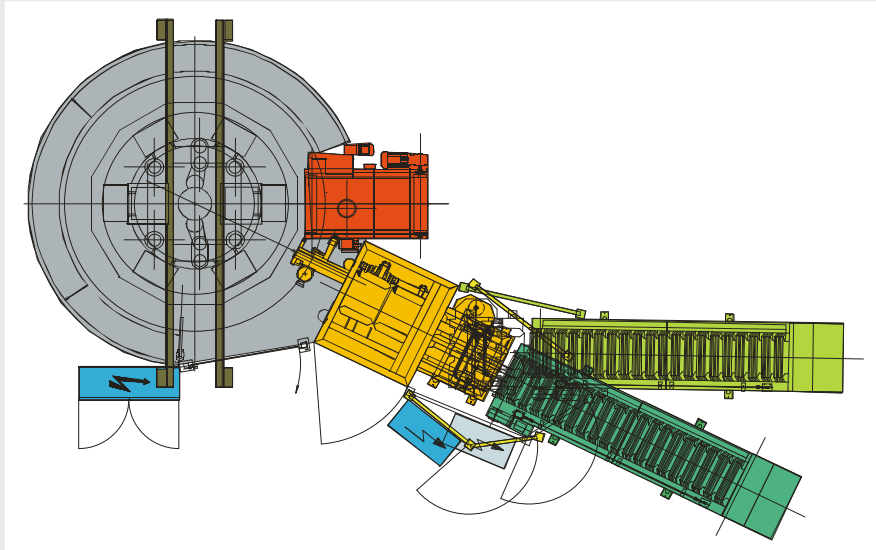

ROTOPACKER 6 RLE

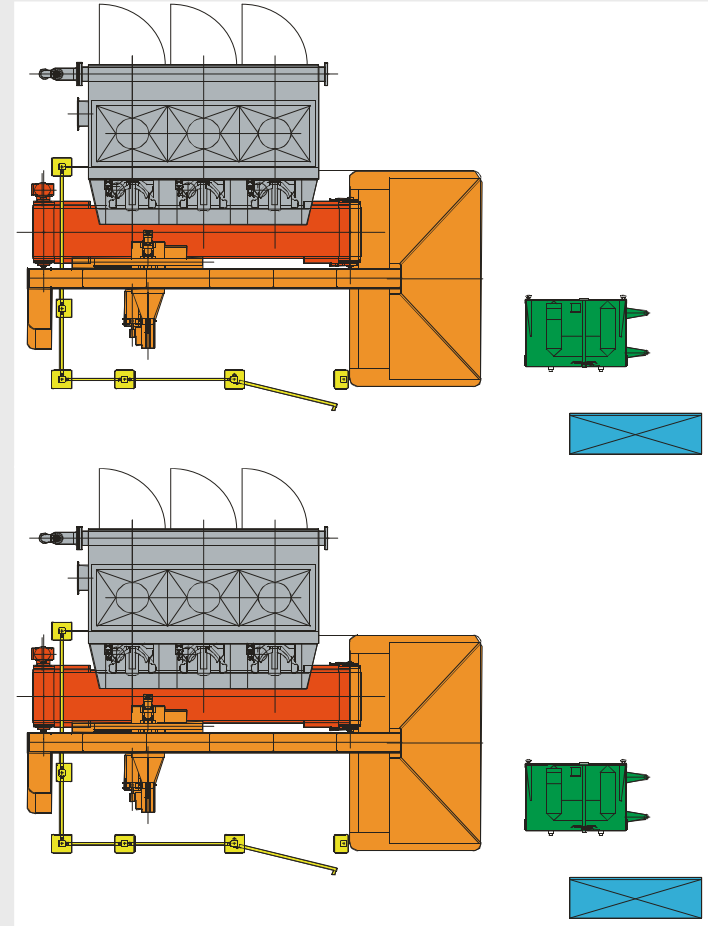

2 x Inline - Packer 3 LEV



■ **lower investment and operating costs**

less space requirement / building cost

only 1 product feed
only 1 discharge line
only 1 spillage system

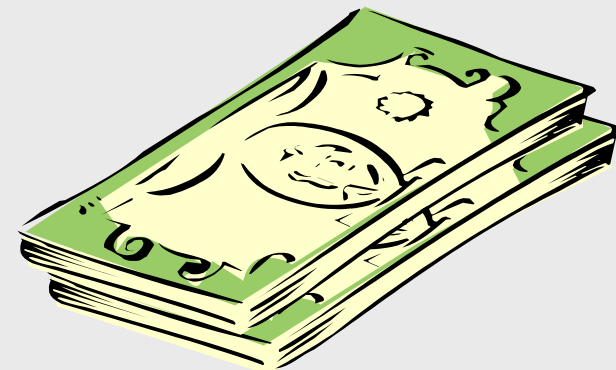

only 1 bag placer or
only 1 operator for manual bag application

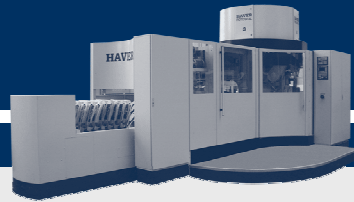

■ **higher output**

no waiting time for bag placing due to constant turning of packer (automatic / manual placing)

no waiting time for bag discharge

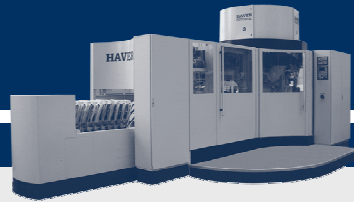

■ **dust protection of operator / bag placer**

the operator / bag placer stands outside of the filling and bag discharge zone



■ **easier to palletize
or load on truck**

**due to constant bag stream
and equal distance between
the bags**



■ **highest flexibility for truck loading**

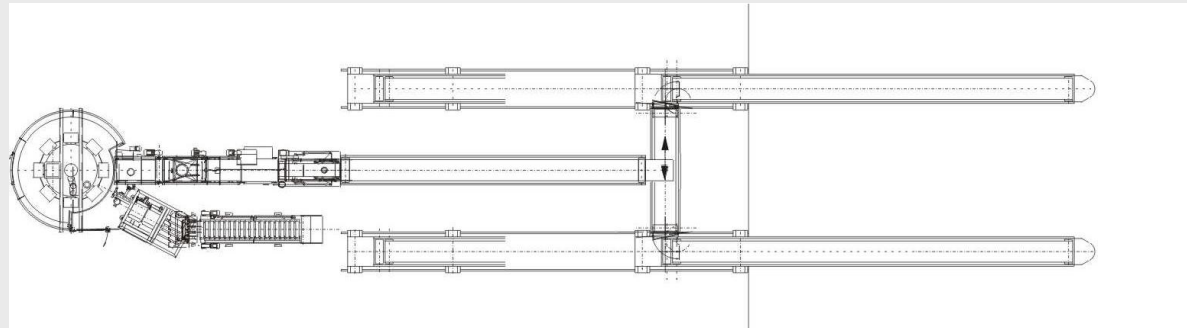

**higher capacity, no waiting times
no reduction during truck change**

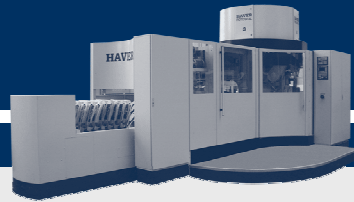

automatic product change

manual purging

critical product change
-contamination not acceptable -

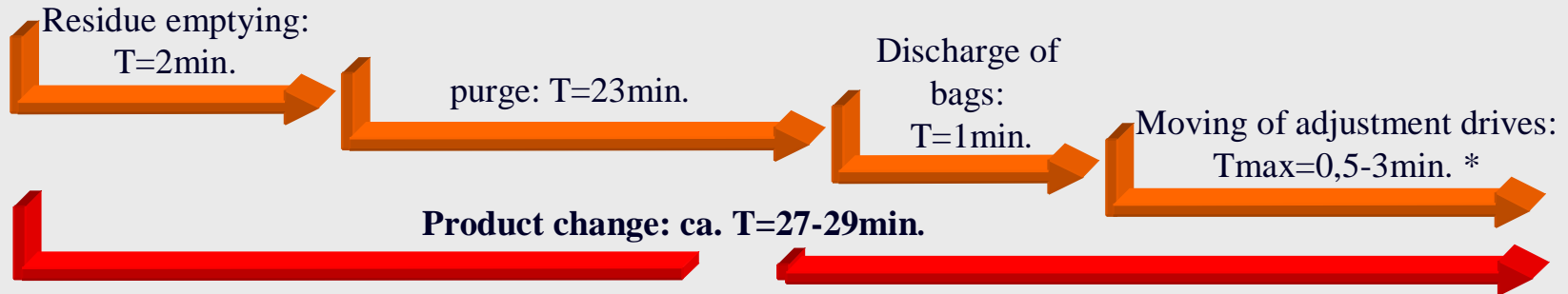

automatic purging 6 RLE

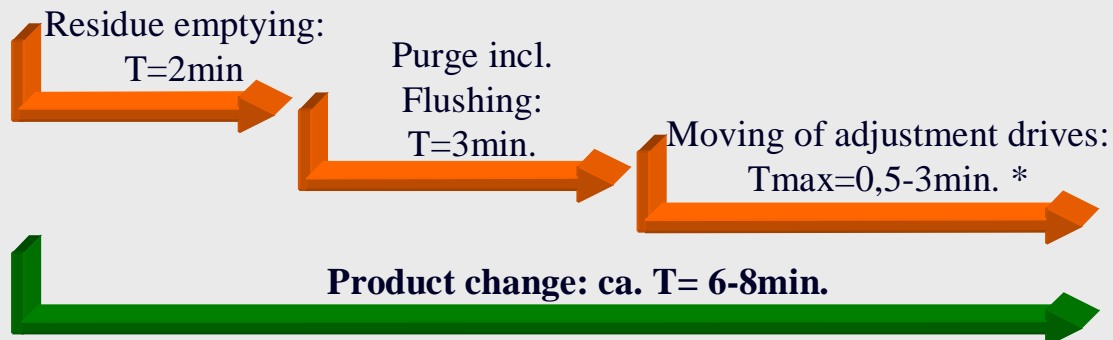

* Depends of the different length of the empty bags



Expansion

ROTO-Packers can be prepared for later expansion :

- e.g. a ROTO-Packer Type 8(4) RLE is equipped with 4 filling spouts in a first step
- easy doubling of capacity while keeping the product feed, bag placer, discharge conveyor line...

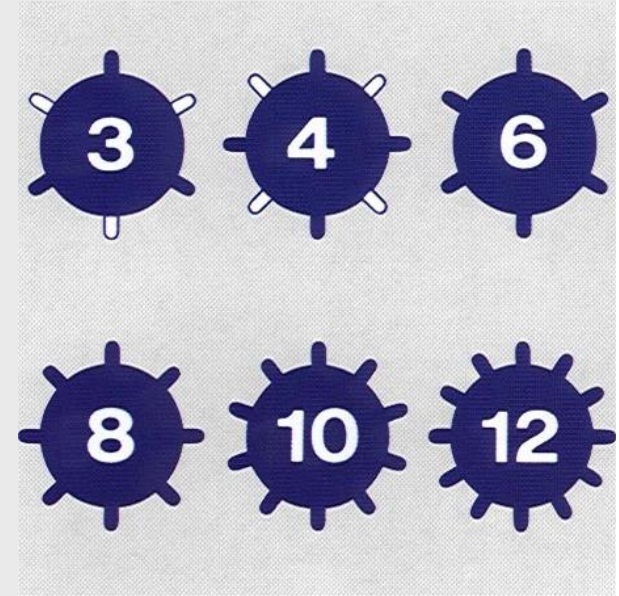

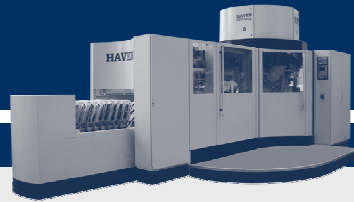

Automation

- every HAYER ROTO-Packer can easily be automated by a bag placer Type RADIMAT



HAYER Bag Placer Type RADIMAT



highest speed and reliability

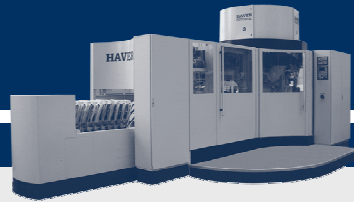

Valve Bag Technology

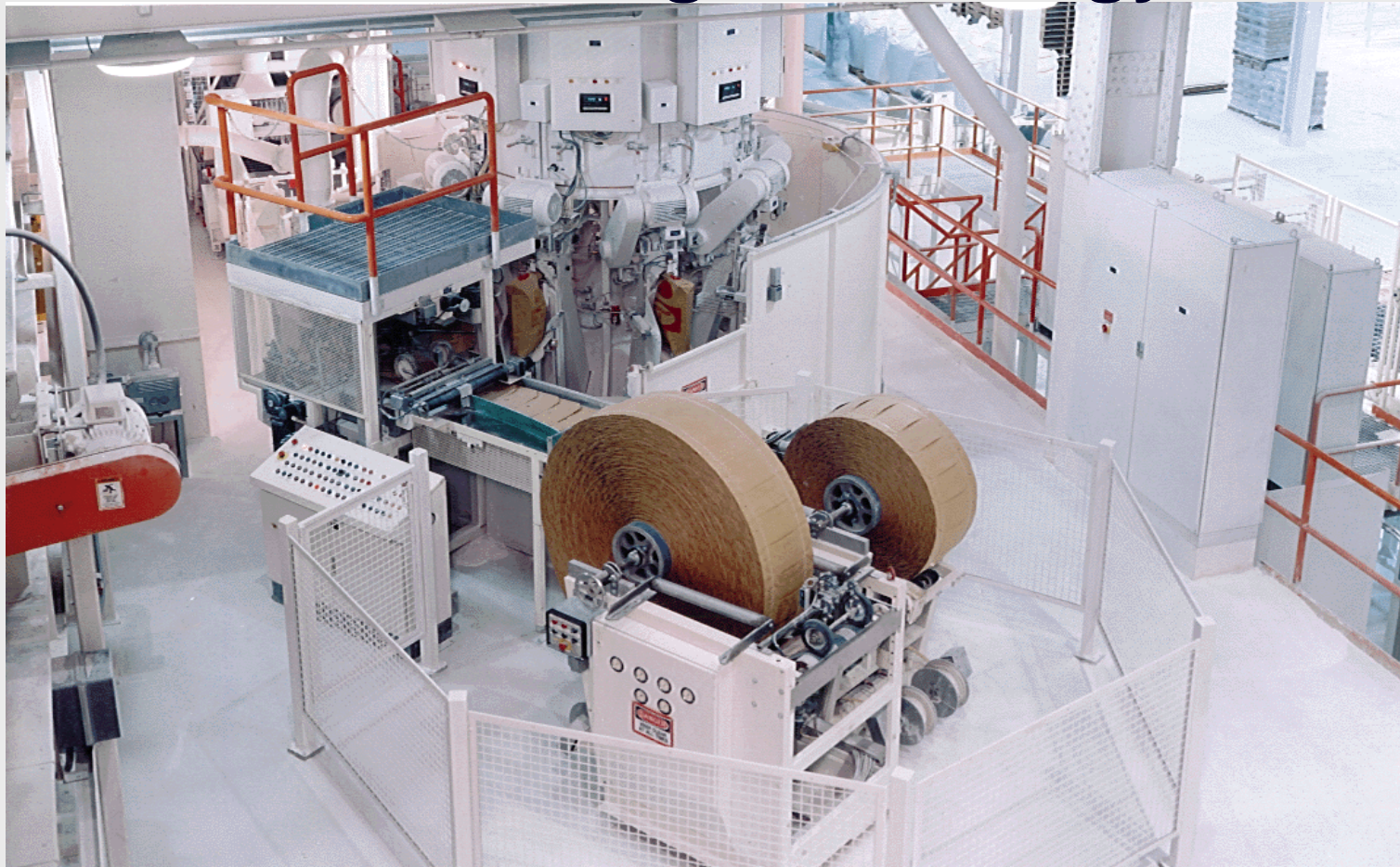

Turtable double reel magazine

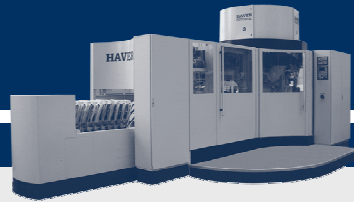

Automation

- every HAVER ROTO-Packer can easily be automated by a bag placer Type RADIMAT
- every HAVER ROTO-Packer is prepared for retrofitting of ULTRA-SONIC sealing technology

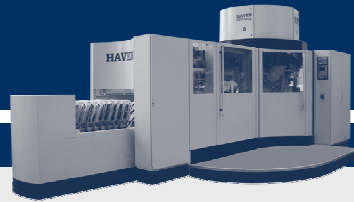

The sealing station

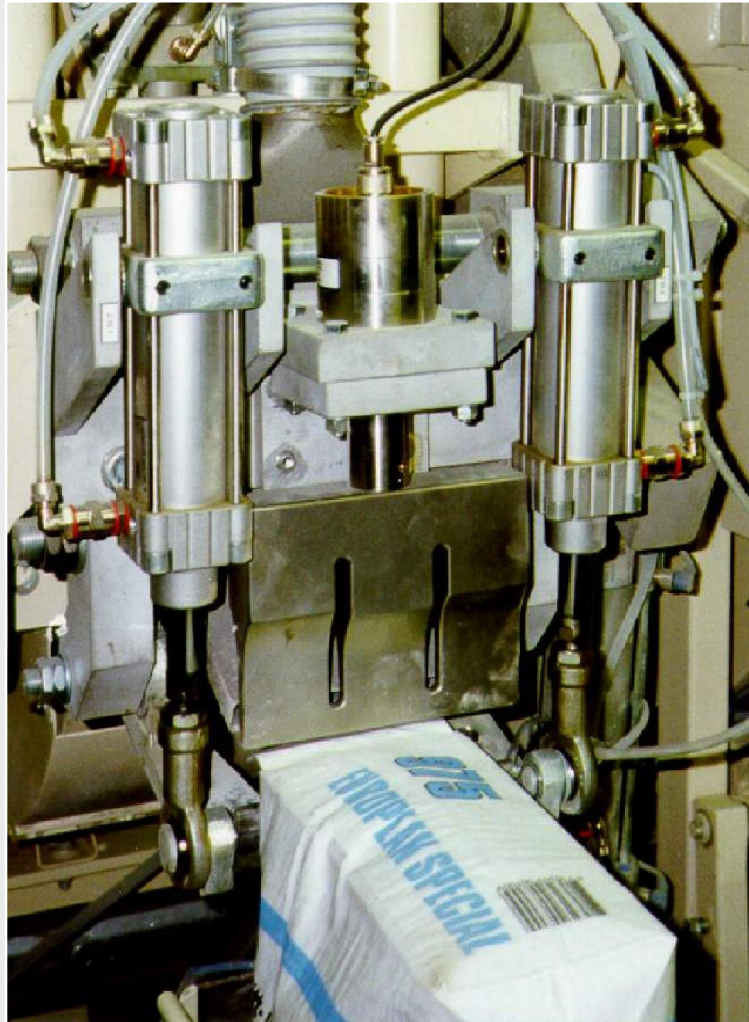

- short welding times
- self cleaning effect
- cool welding tools
- „no“ wear and tear
- highest sealing rate
- low maintenance
- a minimum of mechanical moving parts



Your customer's high satisfaction

- **perfectly clean bags**
- **high weight accuracy**
- **high bag filling degree / compact bags**
- **protection for / of product**
no possibility of product contamination
- **safer transportation of stable pallets**





Decreased operation costs

fewer components:

- simple bag discharge line
- no bag cleaning station
- spillage collecting funnels
- spillage conveyors

■ energy costs

■ dumping costs



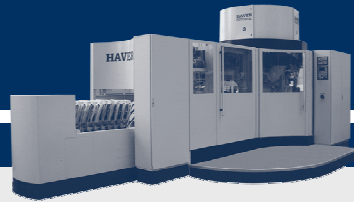

clean working environment





Decreased operation costs

- **filter costs**
- **higher reliability**
- **extended machine lifetimes**
- **cleaning costs**

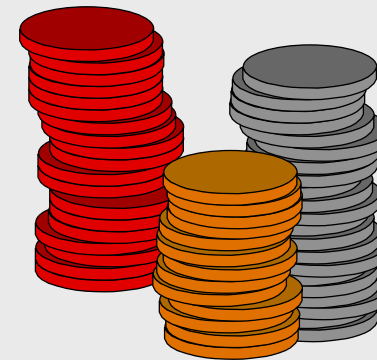



Clean and compact bags



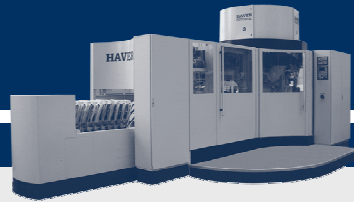

The Idea:



Integration of all modules (including electrical installation) in one main machine frame

“Plug and Pack” Concepts

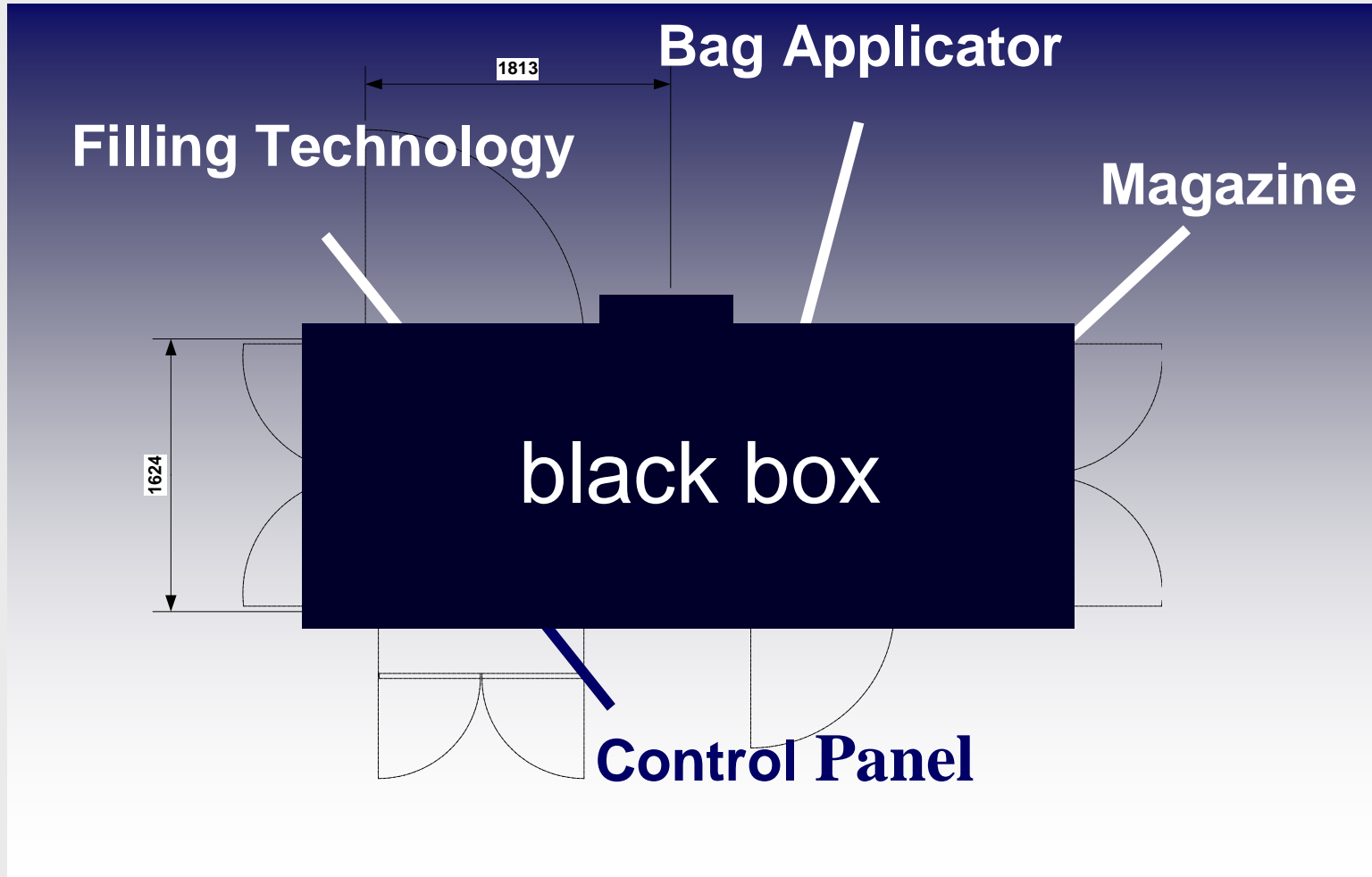
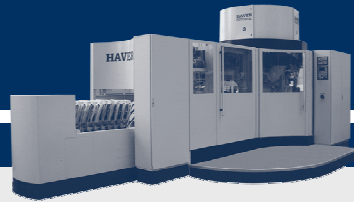

- wired and tubed to one power and air connection point



4th global lime
CONFERENCE • EXHIBITION 2009



Engelbert Koess
Haver & Boecker,
Oelde / GERMANY